



THE WALL-MOUNT™ AIR CONDITIONERS - 10.0 EER, (60HZ)

Models W18AA to W72AA	Right-Side Control Panel
Models W18LA to W72LA	Left-Side Control Panel
1.5 to 6 Ton	(17,000 to 71,000 Btuh)

GREEN REFRIGERANT R-410A

The Bard Wall-Mount Air Conditioner is a self contained energy efficient system, which is designed to offer maximum indoor comfort at a minimal cost without using valuable indoor floor space or outside ground space. This unit is the ideal product for versatile applications such as: new construction, modular offices, school modernization, telecommunication structures, portable structures or correctional facilities. Factory or field installed accessories are available to meet specific job requirements.

Engineered Features

Aluminum Finned Copper Coils:

Grooved tubing and enhanced louvered fin for maximum heat transfer and energy efficiency.

Twin Blowers:

Move air quietly. Most models feature multispeed blower motors providing airflow adjustment for high and low static operation. Motor overload protection is standard on all models.

Air Conditioner Compressor:

Scroll Compressors eliminate need for crankcase heater. Standard on all models, except 5-Ton.

R-410A Refrigerant:

Designed with R-410A (HFC) non-ozone depleting refrigerant in compliance with the Montreal protocol and 2010 EPA requirements.

Phase Rotation Monitor:

Standard on all 3-phase scroll compressors. Protects against reverse rotation if power supply is not properly connected. Rotation protection is not required on the 5-Ton Unit(s).

Galvanized 20 Gauge Zinc Coated Steel Cabinet:

Cleaned, rinsed, sealed and dried before the polyurethane primer is applied. The cabinet is handsomely finished with a baked on textured enamel, which allows it to withstand 1000 hours of salt spray tests per ASTM B117-03.

Foil Faced Insulation:

Standard on all units.

Full Length Mounting Brackets:

Built into cabinet for improved appearance and easy installation.

NOTE: Bottom mounting bracket included to assist in installation.

Electrical Components:

Are easily accessible for routine inspection and maintenance through a right side, service panel opening. Features a lockable, hinged access cover to the circuit breaker or toggle disconnect switch.

Electric Heat Strips:

Features an automatic limit and thermal cut-off safety control. Heater packages can be factory or field installed.

Filter Service Door:

Separate service door provides easy access for filter change.

One Inch, Disposable Air Filters:

Are standard equipment. Optional one inch washable filters available and filter racks permit the addition of 2" pleated filter. Factory or field installed.

Condenser Fan and Motor Shroud Assembly:

Slides out for easy access.

Barometric Fresh Air Damper:

Standard on all units. Allows up to 25% outside fresh air. Optional ventilation packages available.

Built-in Circuit Breakers:

Standard on all electric heat versions of single (230/208 volt) and three phase (230/208 volt) equipment. Toggle disconnects are standard on all electric heat versions of three phase (460 volt) equipment.

Slope Top:

Standard feature for water run-off.

Top Rain Flashing:

Standard feature on all models.

Freezestat:

Standard on W72 models. Optional field installed CMC-29 can be used on all other models.

**Liquid Line Filter Drier:**

Standard on all units. Protects system against moisture.

Compressor Control Module:

Standard on all units. Built-in off-delay timer adjustable from 30 seconds to 5 minutes. 2-minute on-delay if power interrupt. 120-second bypass for low pressure control, and both soft and manual lockouts for high and low pressure controls. Alarm output for alarm relay.

High & Low Pressure Switches are Auto-Reset:

Standard on all units. Built-in lockout circuit resets from the room thermostat. Provides commercial quality protection to the compressor.



- Complies with efficiency requirements of ASHRAE/IESNA 90.1-2013.
- Certified to ANSI/ARI Standard 390-2003 for SPVU (Single Package Vertical Units).
- Intertek ETL Listed to Standard for Safety Heating and Cooling Equipment ANSI/UL 1995/CSA 22.2 No. 236-05, Fourth Edition.
- Commercial Product - Not intended for Residential application.

Capacity and Efficiency Ratings

Models	W18AA W18LA	W24AA W24LA	W30AA W30LA	W36AA W36LA	W42AA W42LA	W48AA W48LA	W60AA W60LA	W72AA W72LA
Cooling Capacity BTUH ①	17,000	24,600	30,000	36,400	41,500	48,000	59,000	71,000
EER	10.00	10.20	10.30	10.00	10.00	10.00	10.00	10.00

① Capacity is certified in accordance with ANSI/ARI Standard 390-2003.

② EER = Energy Efficiency Ratio and is certified in accordance with ANSI/ARI Standard 390-2003.

All ratings based on fresh air intake being 100% closed (no outside air introduction).

Specifications 1-1/2 Ton through 3 Ton

MODELS	W18AA-A W18LA-A	W24AA-A W24LA-A	W24AA-B W24LA-B	W24AA-C W24LA-C	W30AA-A W30LA-A	W30AA-B W30LA-B	W30AA-C W30LA-C	W36AA-A W36LA-A	W36AA-B W36LA-B	W36AA-C W36LA-C
Electrical Rating – 60 Hz	230/208 - 1	230/208 - 1	230/208 - 3	460 - 3	230/208 - 1	230/208 - 3	460 - 3	230/208 - 1	230/208 - 3	460 - 3
Operating Voltage Range	197-253	197-253	197-253	414-506	197-253	197-253	414-506	197-253	197-253	414-506
Compressor--Circuit A										
Voltage	230/208	230/208	230/208	460	230/208	230/208	460	230/208	230/208	460
Rated Load Amps	6.0/6.8	9.2/10.6	6.0/6.9	4.3	10.5/12.0	6.6/7.5	3.6	13.4/15	9.9/11.1	5.1
Branch Circuit Selection Current	9.0	12.8	8.3	5.1	16.0	10.0	4.7	17.9	13.2	6.0
Lock Rotor Amps	48/48	64/64	58/58	28	77/77	71/71	38	112/112	88/88	44
Compressor Type	Scroll	Scroll	Scroll	Scroll	Scroll	Scroll	Scroll	Scroll	Scroll	Scroll
Fan Motor & Condenser										
Fan Motor--HP--RPM	1/5 - 1075	1/5 - 1075	1/5 - 1075	1/5 - 1075	1/5 - 1075	1/5 - 1075	1/5 - 1075	1/5 - 1075	1/5 - 1075	1/5 - 1075
Fan Motor--Amps	1.2	1.2	1.2	0.8	1.5	1.5	0.8	1.5	1.5	0.8
Fan--DIA/CFM	18" - 1800	18" - 1800	18" - 1800	18" - 1800	20" - 2400	20" - 2400	20" - 2400	20" - 2200	20" - 2200	20" - 2200
Blower Motor & Evap.										
Blower Motor--HP-RPM-SPD	1/6-1100-2	1/6-1100-1	1/6-1100-1	1/6-1100-1	1/3-1100-2	1/3-1100-2	1/3-1100-2	1/3-1100-2	1/3-1100-2	1/3-1100-2
Blower Motor--Amps	0.8	1.1	1.1	.45	2.0	2.0	1.0	2.0	2.0	1.0
Motor Type	PSC	PSC	PSC	PSC	PSC	PSC	PSC	PSC	PSC	PSC
CFM Cooling & E.S.P. w/Filter (Rated-Wet Coil)	600 - .35	800 - .30	800 - .30	800 - .30	1000 - .45	1000 - .45	1000 - .45	1100 - .30	1100 - .30	1100 - .30
Filter Sizes (inches) STD.	16x25x1	16x25x1	16x25x1	16x25x1	16x30x1	16x30x1	16x30x1	16x30x1	16x30x1	16x30x1
Shipping Weight --LBS.	330	320	320	320	360	360	360	385	385	385

Specifications 3-1/2 Ton through 6 Ton

MODELS	W42AA-A W42LA-A	W42AA-B W42LA-B	W42AA-C W42LA-C	W48AA-A W48LA-A	W48AA-B W48LA-B	W48AA-C W48LA-C	W60AA-A W60LA-A	W60AA-B W60LA-B	W60AA-C W60LA-C	W72AA-A W72LA-A	W72AA-B W72LA-B	W72AA-C W72LA-C
Electrical Rating – 60 Hz	230/208-1	230/208-3	460-3	230/208-1	230/208-3	460-3	230/208-1	230/208-3	460-3	230/208-1	230/208-3	460-3
Operating Voltage Range	197-253	197-253	414-506	197-253	197-253	414-506	197-253	197-253	414-506	197-253	197-253	414-506
Compressor--Circuit A												
Voltage	230/208	230/208	460	230/208	230/208	460	230/208	230/208	460	230/208	230/208	460
Rated Load Amps	15.1/16.9	10.4/11.6	5.2	17.3/19.6	11.8/13.3	5.8	21.8/23.2	13.9/14.8	7.4	27.7/30.4	16.9/18.5	8.8
Branch Circuit Selection Current	19.9	13.6	6.1	21.4	14.5	6.3	23.2	14.8	7.4	36.9	22.4	10.6
Lock Rotor Amps	109/109	83.1/83.1	41	135/135	98/98	55	130/130	110/110	55	185/185	149/149	75
Compressor Type	Scroll	Scroll	Scroll	Scroll	Scroll	Scroll	Recip.	Recip.	Recip.	Scroll	Scroll	Scroll
Fan Motor & Condenser												
Fan Motor--HP--RPM-SPD	1/3-825-2	1/3-825-2	1/3-825-1	1/3-825-2	1/3-825-2	1/3-825-1	1/3-825-2	1/3-825-2	1/3-825-1	1/2-1075-1	1/2-1075-1	3/4-1075-1
Fan Motor--Amps	2.6	2.6	1.3	2.6	2.6	1.3	2.5	2.5	1.3	4.0	4.0	1.7
Fan--DIA/CFM	24" - 2900	24" - 2900	24" - 2900	24" - 3000	24" - 3000	24" - 3000	24" - 3100	24" - 3100	24" - 3100	24" - 4000	24" - 4000	24" - 4000
Blower Motor & Evap.												
Blower Motor--HP-RPM-SPD	1/3-985-2	1/3-985-2	1/3-985-2	1/3-985-2	1/3-985-2	1/3-985-2	1/2-1070-2	1/2-1070-2	1/2-1070-2	3/4-1035-2	3/4-1035-2	3/4-1035-2
Blower Motor--Amps	2.3	2.3	1.2	2.3	2.3	1.2	3.5	3.5	2.1	6.3	6.3	1.7
Motor Type	PSC	PSC	PSC	PSC	PSC	PSC	PSC	PSC	PSC	ECM	ECM	ECM
CFM Cooling & E.S.P. w/Filter (Rated-Wet Coil)	1350 - .40	1350 - .40	1350 - .40	1550 - .35	1550 - .35	1550 - .35	1800 - .30	1800 - .30	1800 - .30	1900 - .25	1900 - .25	1900 - .25
Filter Sizes (inches) STD.	20x30x1	20x30x1	20x30x1	20x30x1	20x30x1	20x30x1	20x30x1	20x30x1	20x30x1	20x30x1	20x30x1	20x30x1
Shipping Weight --LBS.	475	475	475	485	485	485	550	550	550	550	550	550

Ventilation System Packages

Bard Wall-Mounts are designed to provide optional ventilation packages to meet all of your ventilation and indoor air quality requirements. All units are equipped with a barometric fresh air damper as the standard ventilation package. All ventilation packages can be built-in at the factory or field-installed at a later date.

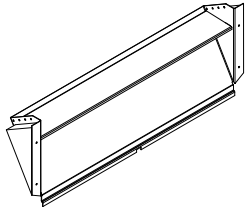

Barometric Fresh Air Damper

MIS-3754

BAROMETRIC FRESH AIR DAMPER - WBFAD

STANDARD

The barometric fresh air damper is a standard feature on all models. It is installed on the inside of the service door and allows outside ventilation air, up to 25% of the total airflow rating of the unit, to be introduced through the air inlet openings and to be mixed with the conditioned air. The damper opens during blower operation and closes when the blower is off. Adjustable blade stops allow different amounts of outside air to be introduced into the building and can be easily locked closed if required.

BLANK OFF PLATE - WBOP

OPTIONAL

A blank off plate is installed on the inside of the service door. It covers the air inlet openings, which restricts any outside air from entering the unit. The blank off plate should be utilized in applications where outside air is not required to be mixed with the conditioned air.

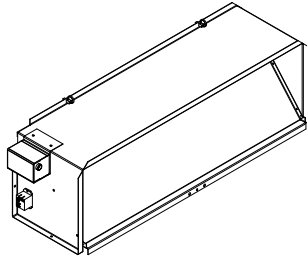

Motorized Fresh Air Damper

MIS-3755

MOTORIZED FRESH AIR DAMPER - WMFAD

OPTIONAL

The motorized fresh air damper is internally mounted behind the service door and allows outside ventilation air, up to 25% of the total airflow rating of the unit, to be introduced through the air inlet openings and to be mixed with the conditioned air. The two position damper can be fully open or closed. The damper blade is powered open by a 24VAC motor with spring return on power loss. The damper can be controlled by indoor blower operation or can be field connected to be managed based on building occupancy.

NOTE: The above vent systems are intake only without built-in exhaust capability. Building will likely require separate field installed barometric relief or mechanical exhaust elsewhere within the conditioned space. Balancing dampers in the return air grille may be required to achieve specified amount of outdoor air intake.

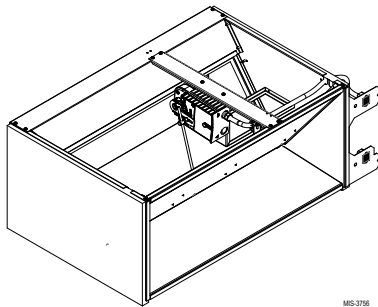

Commercial Room Ventilator

MIS-3756

COMMERCIAL ROOM VENTILATOR - WCRV

OPTIONAL

The built-in commercial room ventilator is internally mounted behind the service door and allows outside ventilation air, up to 100% of the total airflow rating of the unit. It includes a built-in exhaust air damper for room pressurization relief.

The commercial room ventilator (CRV) is a simple and innovative approach to improving the indoor air quality by providing fresh air intake and exhaust capability through the CRV. The damper can be easily adjusted to control the amount of fresh air supplied into the building. The CRV can be controlled by indoor blower operation or field controlled based on room occupancy. Two versions available (except on 1.5 and 2-Ton models). The CRV and CRVS are power open - spring return on power loss, with positive shut-off. Complies with ANSI/ASHRAE Standard 62.1 "Ventilation for Acceptable Indoor Air Quality".

Standard Features:

- Fully modulating
- Honeywell Hi-Torque Actuator with 0-10V signal input capability
- 7" intake hood with filter
- Simple single blade design
- Positive shut-off with non-stick gaskets
- Solid State Controller with occupancy CFM setting and modulating 4-20 mA thermostat signal input

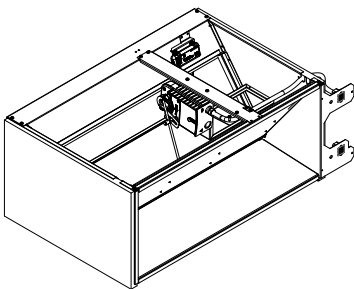

Economizer

MIS-3757

ECONOMIZER – WECO Series

OPTIONAL

The built-in economizer is internally mounted behind the service door and allows outside ventilation air, up to 100% of the total airflow rating of the unit. It includes a built-in exhaust air damper for room pressurization relief. The economizer is designed to provide "free cooling" when outside air conditions are cool and dry enough to satisfy cooling requirements without running the compressor. This in turn provides lower operating costs, while extending the life of the compressor.

Standard Features:

- Full rated outdoor intake
- Fully modulating
- Honeywell Hi-Torque Actuator
- 7" intake hood with filter
- Simple single blade design
- Positive shut-off with non-stick gaskets
- Electronic DB and/or Enthalpy sensors depending upon version
- Honeywell JADE electronic economizer module with precision settings and diagnostics
- DB or Enthalpy economizer versions available

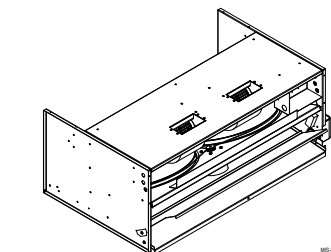

Energy Recovery Ventilator

MIS-3758

WALL-MOUNT ENERGY RECOVERY VENTILATOR - WERV

OPTIONAL

The wall-mount energy recovery ventilator (ERV) is a highly innovative approach to meeting indoor air quality ventilation requirements as established by ANSI/ASHRAE Standard 62.1. The ERV allows from 200 to 450 CFM (depending upon model) of fresh air and exhaust through the unit while maintaining superior indoor comfort and humidity levels. In most cases this can be accomplished without increasing equipment sizing or operating costs. Heat transfer efficiency is up to 67% during summer and 75% during winter conditions.

The ERV consists of a unique "rotary energy recovery cassette" that provides effective sensible and latent heat transfer capabilities during summer and winter conditions. Various control schemes are addressed including limiting ventilation during building occupancy only.

The ERV is designed to be internally mounted behind the service door in the W**A or W**L model wall-mount units. It can be built-in at the factory (W**A only) or field installed as an option. ERVP-*3 and ERVP-*5 can be independently adjusted for intake and exhaust rates.

The ERV's have exhaust gravity shut-off dampers and motorized air intake dampers for positive shut-off.

Wiring includes plug-in harnesses for easy vent installation and removal.

Commercial Room Ventilator Performance Data - WCRV-2

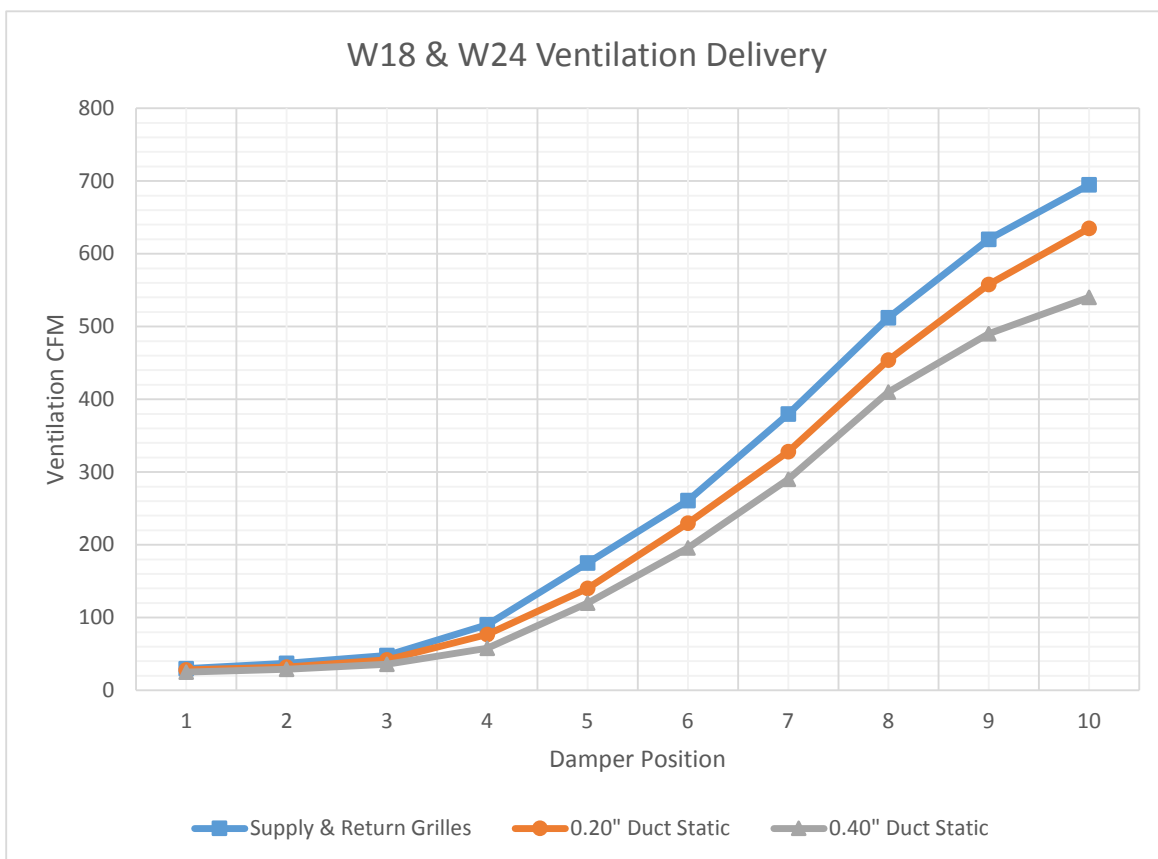

Commercial Room Ventilator Performance Data - WCRVS-3 and WCRVP-3

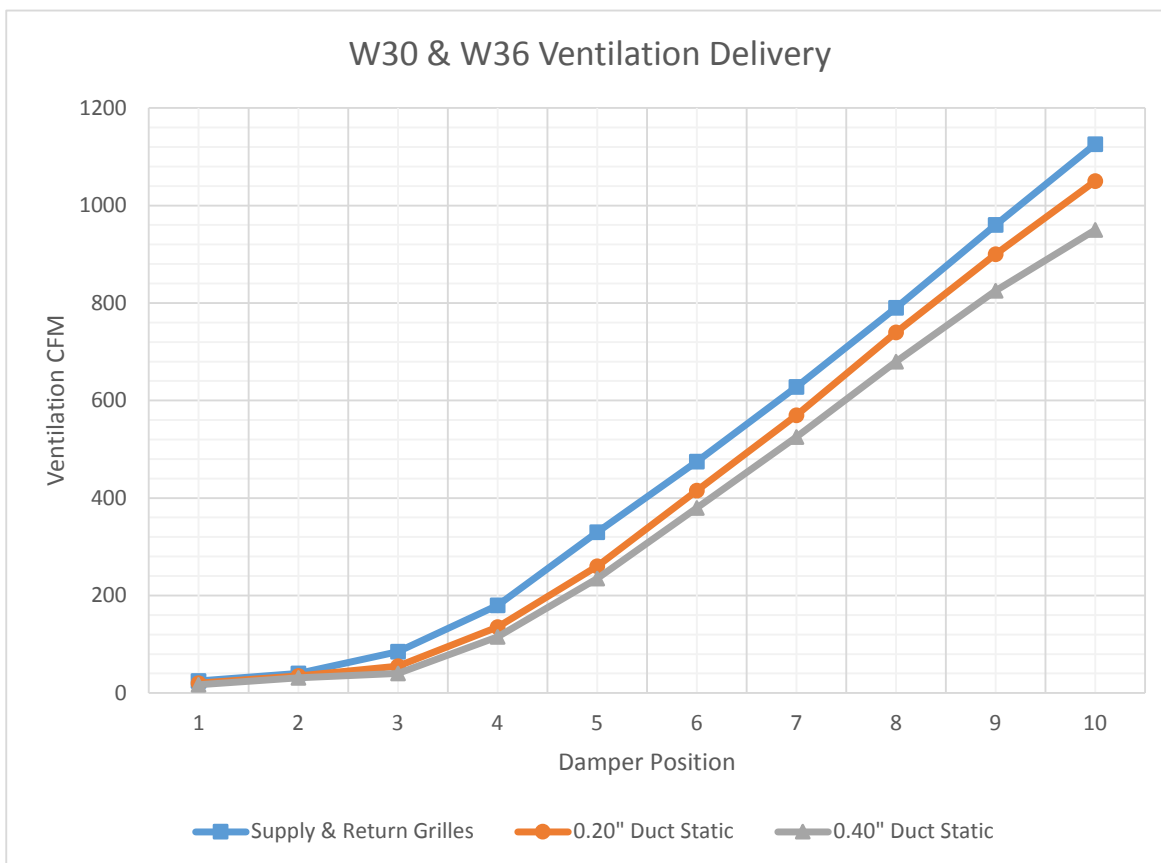

Commercial Room Ventilator Performance Data - WCRVS-5 and WCRVP-5

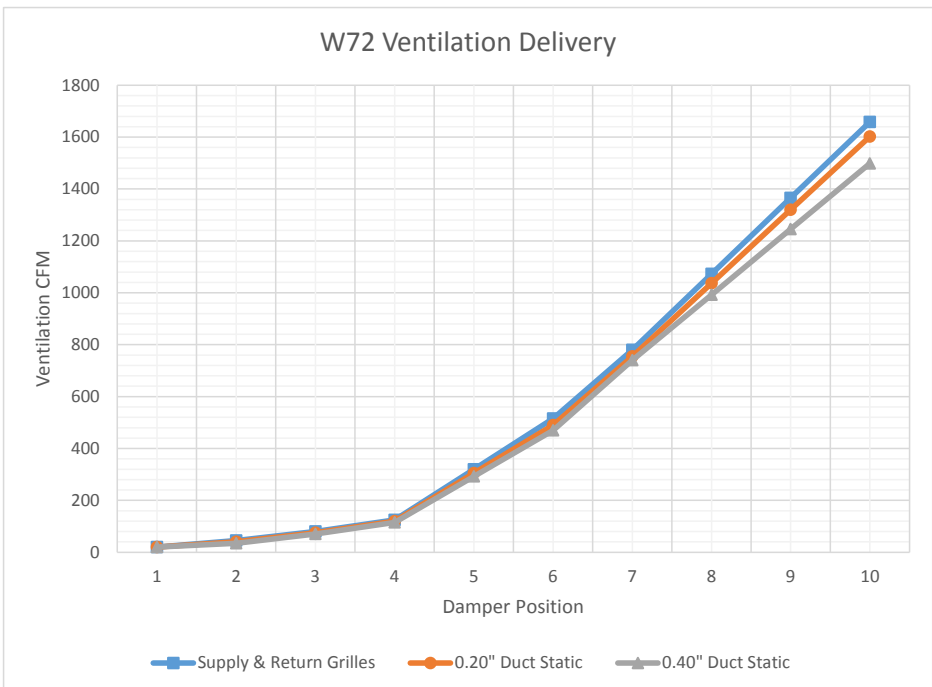
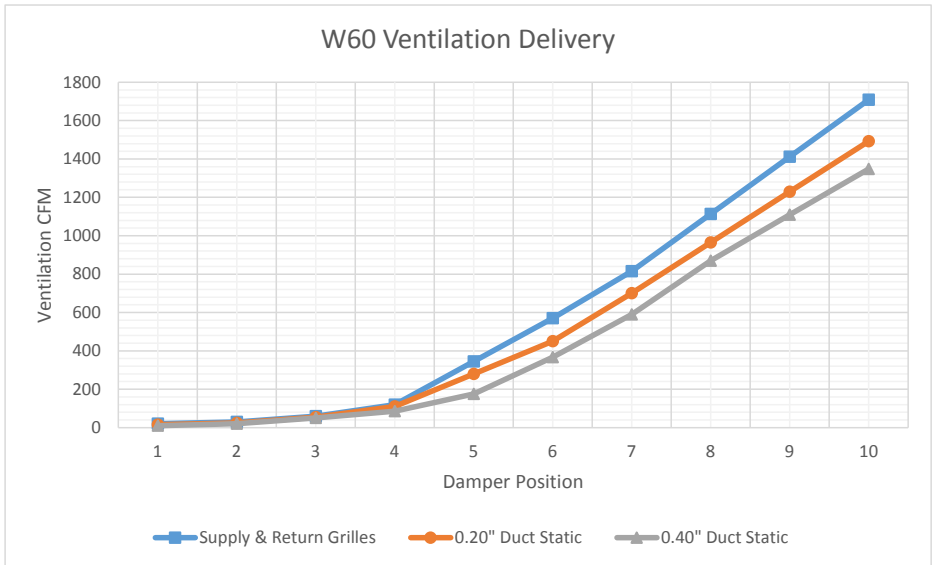
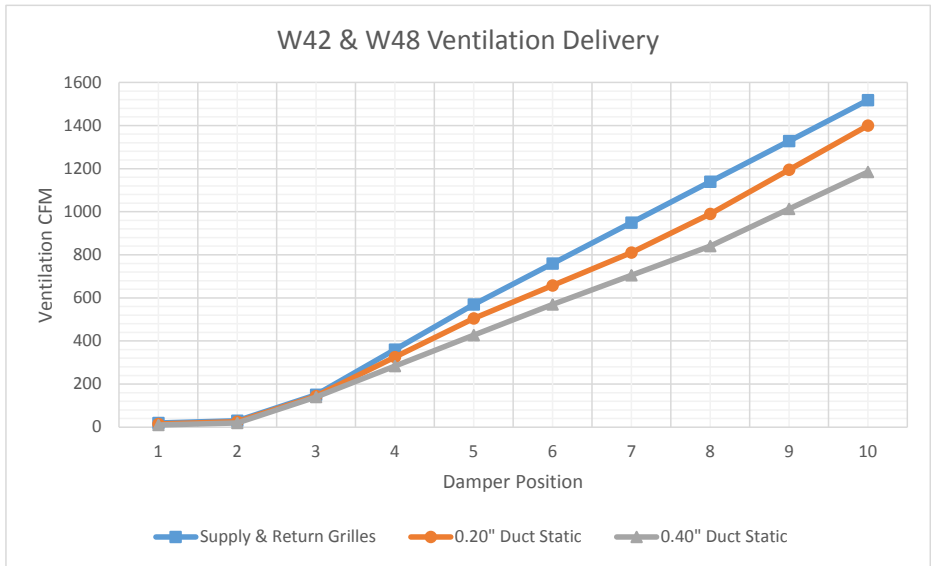

Performance and Application Data- WERVP-A2

SUMMER COOLING PERFORMANCE (INDOOR DESIGN CONDITIONS 75°DB/62°WB)

Ambient O.D.		VENTILATION RATE -- 250 CFM 62% EFFICIENCY						VENTILATION RATE -- 225 CFM 63% EFFICIENCY						VENTILATION RATE -- 200 CFM 63% EFFICIENCY					
DB/WB	F	VLT	VLS	VLL	HRT	HRS	HRL	VLT	VLS	VLL	HRT	HRS	HRL	VLT	VLS	VLL	HRT	HRS	HRL
105	75	11925	8100	1325	7394	5022	822	10727	7287	3441	6758	4591	2168	9540	6480	3060	6010	4082	1928
	70	8100	8100	0	5022	5022	0	7287	7287	0	4591	4591	0	6480	6480	0	4082	4082	0
	65	8100	8100	0	5022	5022	0	7287	7287	0	4591	4591	0	6480	6480	0	4082	4082	0
100	80	17550	6750	10800	10881	4185	6696	15788	6072	9716	9946	3826	6121	14040	5400	8640	8845	3402	5443
	75	11925	6750	5175	7394	4185	3209	10727	6072	4655	6758	3826	2933	9540	5400	4140	6010	3402	2608
	70	6863	6750	113	4255	4185	70	6173	6072	101	3889	3826	64	5490	5400	90	3458	3402	56
	65	6750	6750	0	4185	4185	0	6072	6072	0	3826	3826	0	5400	5400	0	3402	3402	0
95	80	17550	5400	12150	10881	3348	7533	15788	4858	10930	9946	3060	6886	14040	4320	9720	8845	2722	6124
	75	11925	5400	6525	7394	3348	4046	10727	4858	5870	6758	3060	3698	9540	4320	5220	6010	2722	3289
	70	6863	5400	1463	4255	3348	907	6173	4858	1315	3889	3060	829	5490	4320	1170	3458	2722	737
	65	5400	5400	0	3348	3348	0	4858	4858	0	3060	3060	0	4320	4320	0	2722	2722	0
90	80	17550	4050	13500	10881	2511	8370	15788	3643	12145	9946	2295	7651	14040	3240	10800	8845	2041	6804
	75	11925	4050	7875	7394	2511	4883	10727	3643	7084	6758	2295	4463	9540	3240	6300	6010	2041	3969
	70	6863	4050	2813	4255	2511	1744	6173	3643	2530	3889	2295	1594	5490	3240	2250	3458	2041	1417
	65	4050	4050	0	2511	2511	0	3643	3643	0	2295	2295	0	3240	3240	0	2041	2041	0
85	80	17550	2700	14850	10881	1674	9207	15788	2429	13359	9946	1530	8416	14040	2160	11880	8845	1361	7484
	75	11925	2700	9225	7394	1674	5720	10727	2429	8298	6758	1530	5228	9540	2160	7380	6010	1361	4649
	70	6863	2700	4163	4255	1674	2581	6173	2429	3744	3889	1530	2359	5490	2160	3300	3458	1361	2098
	65	2700	2700	0	1674	1674	0	2429	2429	0	1530	1530	0	2160	2160	0	1361	1361	0
80	75	11925	1350	10575	7394	837	6557	10727	1214	9513	6758	765	5993	9540	1080	8460	6010	680	5330
	70	6863	1350	5513	4255	837	3418	6173	1214	4959	3889	765	3124	5490	1080	4410	3458	680	2778
	65	2363	1350	1013	1465	837	628	2125	1214	911	1339	765	547	1890	1080	810	1190	680	510
	60	1350	1350	0	837	837	0	1214	1214	0	765	765	0	1080	1080	0	680	680	0
75	70	6863	0	6863	4255	0	4255	6173	0	6173	6889	0	3889	5490	0	5490	3458	0	3458
	65	2363	0	2363	1465	0	1465	2125	0	2125	1339	0	1339	1890	0	1890	1190	0	1190
	60	0	0	0	0	0	0	0	0	0	0	0	0	0	0	0	0	0	0

WERVP-A2 WINTER HEATING PERFORMANCE (INDOOR DESIGN CONDITIONS 70°F DB)

Ambient O.D.	VENTILATION RATE					
	250 250 CFM 74% EFF.		225 CFM 75% EFF.		200 CFM 75% EFF.	
DB/°F	WVL	WHR	WVL	WHR	WVL	WHR
65	1350	999	1214	911	1080	810
60	2700	1998	2429	1822	2160	1620
55	4050	2997	3643	2733	3240	2430
50	5400	3996	4858	3643	4320	3240
45	6750	4995	6072	4554	5400	4050
40	8100	5994	7287	5465	6480	4860
35	9450	6993	8501	6376	7560	5670
30	10800	7992	9716	7287	8640	6480
25	12150	8991	10930	8198	9720	7290
20	13500	9990	12145	9108	10800	8100
15	14850	10989	13359	10019	11880	8910

LEGEND:

- VLT = Ventilation Load - Total
- VLS = Ventilation Load - Sensible
- VLL = Ventilation Load - Latent
- HRT = Heat Recovery - Total
- HRS = Heat Recovery - Sensible
- HRL = Heat Recovery - Latent
- WVL = Winter Ventilation Load
- WHR = Winter Heat Recovery

NOTE: Sensible performance only is shown for winter application.

Performance and Application Data- WERVP-3

SUMMER COOLING PERFORMANCE
(INDOOR DESIGN CONDITIONS 75°F DB/62°F WB)

Ambient O.D.	VENTILATION RATE -- 400CFM						VENTILATION RATE -- 325 CFM						VENTILATION RATE -- 250 CFM						
	63% EFFICIENCY			64% EFFICIENCY			64% EFFICIENCY			65% EFFICIENCY			65% EFFICIENCY			65% EFFICIENCY			
DB/ WB	F	VLT	VLS	VLL	HRT	HRS	HRL	VLT	VLS	VLL	HRT	HRS	HRL	VLT	VLS	VLL	HRT	HRS	HRL
75	19080	12960	6120	12020	8164	3835	15502	10530	4972	9921	6739	3182	11925	8100	3825	7751	5265	2486	
105	70	12960	12960	0	8164	8164	0	10530	10530	0	6739	6739	0	8100	8100	0	5265	5265	0
65	12960	12960	0	8164	8164	0	10530	10530	0	6739	6739	0	8100	8100	0	5265	5265	0	
80	28080	10800	17280	17690	6804	10886	22815	8775	14040	14601	5616	8995	11925	6750	10800	11407	4387	7019	
75	19080	10800	8280	12020	6804	5216	15502	8775	6727	9921	5616	4305	11925	6750	5175	7751	4387	3363	
100	70	10800	180	6717	6804	113	8921	8775	146	5709	5616	93	6862	6750	112	4460	4387	73	
65	10800	10800	0	6804	6804	0	8775	8775	0	5616	5616	0	6750	6750	0	4387	4387	0	
60	10800	10800	0	6804	6804	0	8775	8775	0	5616	5616	0	6750	6750	0	4387	4387	0	
80	28080	8640	19440	17690	5443	12247	22815	7020	15795	14601	4492	10108	12150	5400	12150	11407	3510	7897	
75	19080	8640	10440	12020	5443	6577	15502	7020	8482	9921	4492	5428	11925	5400	6525	7751	3510	4241	
95	70	10800	8640	2340	6917	5443	1474	8921	7020	1901	5709	4492	1216	5862	5400	1462	4460	3510	950
65	8640	8640	0	5443	5443	0	7020	7020	0	4492	4492	0	5400	5400	0	3510	3510	0	
60	8640	8640	0	5443	5443	0	7020	7020	0	4492	4492	0	5400	5400	0	3510	3510	0	
80	28080	6480	21600	17690	4082	13608	22815	5265	17550	17550	3369	11232	4050	4050	13500	11407	2632	8774	
75	19080	6480	12600	12020	4082	7938	15502	5265	10237	9921	3369	6552	11925	4050	7875	7751	2632	5118	
90	70	10800	6480	4500	6917	4082	2835	8921	5265	5709	3369	2340	6862	4050	2812	4460	2632	1828	
65	6480	6480	0	4082	4082	0	5265	5265	0	3369	3369	0	4050	4050	0	2632	2632	0	
60	6480	6480	0	4082	4082	0	5265	5265	0	3369	3369	0	4050	4050	0	2632	2632	0	
80	28080	4320	23760	17690	2721	14968	22815	3510	19305	14601	2246	12355	17550	2700	14850	11407	1755	9652	
75	19080	4320	14760	12020	2721	9298	15502	3510	11982	9921	2246	7625	11925	2700	9225	7751	1755	5996	
85	70	10800	4320	6660	6917	2721	4195	8921	3510	5411	5709	2246	3463	6862	2700	4162	4460	1755	2705
65	4320	4320	0	2721	2721	0	3510	3510	0	2246	2246	0	2700	2700	0	1755	1755	0	
60	4320	4320	0	2721	2721	0	3510	3510	0	2246	2246	0	2700	2700	0	1755	1755	0	
75	19080	2160	16920	12020	1360	10659	15502	1755	13747	9921	1123	8798	11925	1350	10575	7751	877	6873	
80	10800	2160	8820	6917	1360	5556	8921	1755	7166	5709	1123	4586	6862	1350	5512	4460	877	3583	
65	3780	2160	1620	1620	2381	1360	10659	1755	1316	1965	1123	842	2362	1350	1012	1535	877	583	
60	2160	2160	0	1360	1360	0	1755	1755	0	1123	1123	0	1350	1350	0	877	877	0	
70	10800	0	10980	6917	0	6917	8921	0	8921	5709	0	5709	6862	0	5709	6862	4460	0	4460
75	65	3780	0	3780	2381	0	2380	3071	0	3071	1965	0	1965	2362	0	2362	1535	0	1535
60	0	0	0	0	0	0	0	0	0	0	0	0	0	0	0	0	0	0	0

LEGEND:

- VLT = Ventilation Load - Total
- VLS = Ventilation Load - Sensible
- VLL = Ventilation Load - Latent
- HRT = Heat Recovery - Total
- HRS = Heat Recovery - Sensible
- HRL = Heat Recovery - Latent
- WVL = Winter Ventilation Load
- WHR = Winter Heat Recovery

NOTE: Sensible performance only is shown for winter application.

Performance and Application Data- WERVP-5

SUMMER COOLING PERFORMANCE
(INDOOR DESIGN CONDITIONS 75°F DB/62°F WB)

Ambient O.D.	VENTILATION RATE -- 400CFM						VENTILATION RATE -- 325 CFM						VENTILATION RATE -- 250 CFM						
	63% EFFICIENCY			64% EFFICIENCY			64% EFFICIENCY			65% EFFICIENCY			65% EFFICIENCY			65% EFFICIENCY			
DB/ WB	F	VLT	VLS	VLL	HRT	HRS	HRL	VLT	VLS	VLL	HRT	HRS	HRL	VLT	VLS	VLL	HRT	HRS	HRL
75	21465	14580	6884	13952	9477	4475	17887	12150	5737	11805	8018	3786	14310	9720	4590	9387	6512	3075	
105	70	14580	14580	0	9477	9477	0	12150	12150	0	8018	8018	0	9720	9720	0	6512	6512	0
65	14580	14580	0	9477	9477	0	12150	12150	0	8018	8018	0	9720	9720	0	6512	6512	0	
80	31590	12150	19440	20533	7897	12635	26325	10125	16200	17374	6682	10692	21060	8100	12960	14110	5427	8683	
75	21465	12150	9314	13952	7897	6054	17887	10125	7762	11805	6682	5123	14310	8100	6210	9387	5427	4160	
100	70	12352	12150	202	8029	7897	131	10293	10125	168	6793	6682	111	8235	8100	135	5517	5427	90
65	12352	12150	0	7897	7897	0	10125	10125	0	6682	6682	0	8100	8100	0	5427	5427	0	
60	12150	12150	0	7897	7897	0	10125	10125	0	6682	6682	0	8100	8100	0	5427	5427	0	
80	31590	9720	21870	20533	6318	14215	26325	6075	18225	17374	5345	12028	21060	6480	14580	14110	4341	9768	
75	21465	9720	11744	13952	6318	7634	17887	6075	9787	11805	5345	4659	14310	6480	7830	9587	4341	5246	
95	70	12352	9720	2632	8029	6318	1711	10293	8100	2193	6793	5345	1447	8235	6480	1755	5517	4341	1175
65	9720	9720	0	6318	6318	0	8100	8100	0	5345	5345	0	6480	6480	0	4341	4341	0	
60	9720	9720	0	6318	6318	0	8100	8100	0	5345	5345	0	6480	6480	0	4341	4341	0	
80	31590	7290	24300	20533	4738	15794	26325	6075	20250	17374	4009	13365	21060	4860	16200	14110	3256	10854	
75	21465	7290	14175	13952	4738	9213	17887	6075	11812	11805	4009	7796	14310	4860	9450	9587	3256	6331	
90	70	12352	7290	5062	8029	4738	3290	10293	6075	4218	6793	4009	2784	8235	4860	3375	5517	3256	2261
65	7290	7290	0	4738	4738	0	6075	6075	0	4009	4009	0	4860	4860	0	3256	3256	0	
60	7290	7290	0	4738	4738	0	6075	6075	0	4009	4009	0	4860	4860	0	3256	3256	0	
80	31590	4860	26730	20533	3159	17374	26325	4050	22275	17374	2672	14701	21060	3240	17820	14110	2170	11939	
75	21465	4860	16605	16605	10393	17887	4050	13837	4050	13837	11805	2672	9132	14310	3240	11070	9587	2170	7416
85	70	12352	4860	7492	8029	3159	4870	10293	4050	6243	6793	2672	4120	8235	3240	4995	5517	2170	3346
65	4860	4860	0	3159	3159	0	4050	4050	0	2672	2672	0	3240	3240	0	2170	2170	0	
60	4860	4860	0	3159	3159	0	4050	4050	0	2672	2672	0	3240	3240	0	2170	2170	0	
75	21465	2430	19035	13952	1580	12372	17887	2025	15862	11805	1336	10469	14310	1620	12690	9587	1085	8502	
80	12352	2430	9822	8029	1580	6449	10293	2025	8268	6793	1336	5457	8235	1620	6615	5517	1085	4432	
65	4252	2430	1822	2764	1580	1184	3543	2025	1518	2338	1336	1002	2835	1620	1215	1899	1085	814	
60	2430	2430	0	1579	1580	0	1336	2025	0	1336	1336	0	1620	1620	0	1085	1085	0	
70																			

Electrical Specifications — W**AA Series

MODEL	Rated Volts & Phase	No. Field Power Circuits	Single Circuit				Multiple Circuit														
			③ Minimum Circuit Ampacity	① Maximum External Fuse or Ckt. Brkr.	② Field Power Wire Size	② Ground Wire	③ Minimum Circuit Ampacity			① Maximum External Fuse or Ckt. Breaker			② Field Power Wire Size			② Ground Wire Size					
							Ckt. A	Ckt. B	Ckt. C	Ckt. A	Ckt. B	Ckt. C	Ckt. A	Ckt. B	Ckt. C	Ckt. A	Ckt. B	Ckt. C			
W18AA-A00,AOZ A05 A08 A10	230/208-1	1	16	20	12	12															
		1	30	30	10	10															
		1	46	50	8	10															
		1	56	60	6	10															
W24AA-A00, AOZ A04 A05 A08 A10	230/208-1	1	21	30	10	10															
		1	25	30	10	10															
		1	30	30	10	10															
		1	46	50	8	10															
W24AA-B00, BOZ B06	230/208-3	1	15	20	12	12															
		1	22	25	10	10															
		1	9	15	14	14															
			1	11	15	14	14														
W30AA-A00, AOZ A05 A08 A10 A15	230/208-1	1	26	35	8	10															
		1	32	35	8	10															
		1	47	50	8	10															
		1	58	60	6	10															
		1 or 2	84	90	4	8	58	26		60	30		6	10				10	10		
W30AA-B00, BOZ B06 B09 B15	230/208-3	1	19	20	12	12															
		1	24	25	10	10															
		1	33	35	8	10															
		1	51	60	6	10															
W30AA-C00, COZ C06 C09 C12 C15	460-3	1	9	15	14	14															
		1	12	15	14	14															
		1	17	20	12	12															
		1	21	25	10	10															
W36AA-A00, AOZ A05 A08 A10 A15	230/208-1	1	29	35	8	10															
		1	32	35	8	10															
		1	47	50	8	10															
		1 or 2	84	90	4	8	58	26		60	30		6	10				10	10		
W36AA-B00, BOZ B06 B09 B15	230/208-3	1	23	30	10	10															
		1	24	30	10	10															
		1	33	35	8	10															
		1	51	60	6	10															
W36AA-C00, COZ C06 C09 C12 C15	460-3	1	11	15	14	14															
		1	12	15	14	14															
		1	17	20	12	12															
		1	21	25	10	10															
W42AA-A00, AOZ A05 A10 A15 A20	230/208-1	1	32	50	8	10															
		1	32	50	8	10															
		1	58	60	6	10															
		1 or 2	84	90	4	8	58	26		60	30		6	10				10	10		
		1 or 2	110	125	2	6	58	52		60	60		6	6				10	10		
W42AA-B00, BOZ B09 B15 B18	230/208-3	1	25	35	8	10															
		1	33	35	8	10															
		1	51	60	6	10															
		1	60	60	6	10															
W42AA-C00, COZ C09 C15	460-3	1	12	15	14	14															
		1	17	20	12	12															
		1	26	30	10	10															
		1	26	30	10	10															
W48AA-A00, AOZ A05 A10 A15 A20	230/208-1	1	34	50	8	10															
		1	34	50	8	10															
		1	58	60	6	10															
		1 or 2	84	90	4	8	58	26		60	30		6	10				10	10		
		1 or 2	110	125	2	6	58	52		60	60		6	6				10	10		
W48AA-B00, BOZ B09 B15 B18	230/208-3	1	26	35	8	10															
		1	33	35	8	10															
		1	51	60	6	10															
		1	60	60	6	10															
W48AA-C00, COZ C09 C15	460-3	1	12	15	14	14															
		1	17	20	12	12															
		1	26	30	10	10															
		1	26	30	10	10															
W60AA-A00, AOZ A05 A10 A15 A20	230/208-1	1	38	60	8	10															
		1	38	60	8	10															
		1	60	60	6	10															
		1 or 2	86	90	3	8	60	26		60	30		6	10				10	10		
		1 or 2	112	125	2	6	60	52		60	60		6	6				10	10		
W60AA-B00, BOZ B09 B15 B18	230/208-3	1	27	40	8	10															
		1	35	40	8	10															
		1	53	60	6	10															
		2	N/A	N/A	N/A	N/A	35	28		40	30		8	10				10	10		
W60AA-C00, COZ C09 C15	460-3	1	14	20	12	12															
		1	18	20	12	12															
		1	27	30	10	10															
		1	27	30	10	10															
W72AA-A00, AOZ A05 A10 A15 A20	230/208-1	1	58	60	6	10															
		1	58	60	6	10															
		1 or 2	62	70	6	8	58	26		60	30		6	10				10	10		
		1 or 2	88	90	3	8	58	52		60	60		6	6				10	10		
		1 or 3	114	125	2	6	58	52	52	60	60	60	6	6	6			10	10	10	
W72AA-B00, BOZ B09 B15 B18	230/208-3	1	40	60	8	10															
		1	40	60	8	10															
		1	55	60	6	10															
		2	N/A	N/A	N/A	N/A	40	28		60	30		8	10				10	10		
W72AA-C00, COZ C09 C15	460-3	1	18	25	10	10															
		1	18	25	10	10															
		1	27	30	10	10															
		1	27	30	10	10															

① Maximum size of the time delay fuse or HACR type circuit breaker for protection of field wiring conductors.

② Based on 75C copper wire. All wiring must conform to the National Electrical Code and all local codes.

③ These "Minimum Circuit Ampacity" values are to be used for sizing the field power conductors. Refer to the National Electrical code (latest version), Article 310 for power conductor sizing.

Caution: When more than one field power circuit is run through one conduit, the conductors must be derated. Pay special attention to note 8 of Table 310 regarding Ampacity Adjustment Factors when more than three (3) current carrying conductors are in a raceway.

IMPORTANT: While this electrical data is presented as a guide, it is important to electrically connect properly sized over-current protection and conductor wires in accordance with the National Electrical Code and all local codes.

Electrical Specifications — W**LA Series

MODEL	Rated Volts & Phase	No. Field Power Circuits	Single Circuit				Dual Circuit							
			③ Minimum Circuit Ampacity	① Maximum External Fuse or Ckt. Brkr.	② Field Power Wire Size	② Ground Wire	③ Minimum Circuit Ampacity		① Maximum External Fuse or Ckt. Breaker		② Field Power Wire Size		② Ground Wire Size	
							Ckt. A	Ckt. B	Ckt. A	Ckt. B	Ckt. A	Ckt. B	Ckt. A	Ckt. B
W18LA-A00,AOZ	230/208-1	1	16	20	12	12								
A05		1	30	30	10	10								
A08		1	46	50	8	10								
A10		1	56	60	6	10								
W24LA-A00,AOZ	230/208-1	1	21	30	10	10								
A05		1	30	30	10	10								
A08		1	46	50	8	10								
A10		1	56	60	6	10								
W24LA-B00,BOZ	230/208-3	1	15	20	12	12								
B06		1	22	25	10	10								
W24LA-C00,COZ	460-3	1	9	15	14	14								
C06		1	11	15	14	14								
W30LA-A00,AOZ	230/208-1	1	26	35	8	10								
A05		1	32	35	8	10								
A08		1	47	50	8	10								
A10		1	58	60	6	10								
A15		1 or 2	84	90	4	8	58	26	60	30	6	10	10	10
W30LA-B00,BOZ	230/208-3	1	19	20	12	12								
B09		1	33	35	8	10								
B15		1	51	60	6	10								
W30LA-C00,COZ	460-3	1	9	15	14	14								
C09		1	17	20	12	12								
C15		1	26	30	10	10								
W36LA-A00,AOZ	230/208-1	1	29	35	8	10								
A05		1	32	35	8	10								
A10		1	58	60	6	10								
A15		1 or 2	84	90	4	8	58	26	60	30	6	10	10	10
W36LA-B00,BOZ		230/208-3	1	23	30	10	10							
B09	1		33	35	8	10								
B15	1		51	60	6	10								
W36LA-C00,COZ	460-3	1	11	15	14	14								
C09		1	17	20	12	12								
C15		1	26	30	10	10								
W42LA-A00,AOZ	230/208-1	1	32	50	8	10								
A05		1	32	50	8	10								
A10		1	58	60	6	10								
A15		1 or 2	84	90	4	8	58	26	60	30	6	10	10	10
W42LA-B00,BOZ		230/208-3	1	25	35	8	10							
B09	1		33	35	8	10								
B15	1		51	60	6	10								
W42LA-C00,COZ	460-3	1	12	15	14	14								
C09		1	17	20	12	12								
C15		1	26	30	10	10								
W48LA-A00,AOZ	230/208-1	1	34	50	8	10								
A05		1	34	50	8	10								
A10		1	58	60	6	10								
A15		1 or 2	84	90	4	8	58	26	60	30	6	10	10	10
W48LA-B00,BOZ		230/208-3	1	26	35	8	10							
B09	1		33	35	8	10								
B15	1		51	60	6	10								
W48LA-C00,COZ	460-3	1	12	15	14	14								
C09		1	17	20	12	12								
C15		1	26	30	10	10								
W60LA-A00,AOZ	230/208-1	1	38	60	8	10								
A05		1	38	60	8	10								
A10		1	60	60	6	10								
A15		1 or 2	86	90	3	8	60	26	60	30	6	10	10	10
W60LA-B00,BOZ		230/208-3	1	27	40	8	10							
B09	1		35	40	8	10								
B15	1		53	60	6	10								
W60LA-C00,COZ	460-3	1	14	20	12	12								
C09		1	18	20	12	12								
C15		1	27	30	10	10								
W72LA-A00,AOZ	230/208-1	1	58	60	6	10								
A05		1	58	60	6	10								
A10		1 or 2	62	70	6	8	58	26	60	30	6	10	10	10
A15		1 or 2	88	90	3	8	58	52	60	60	6	6	10	10
W72LA-B00,BOZ		230/208-3	1	40	60	8	10							
B09	1		40	60	8	10								
B15	1		55	60	6	10								
W72LA-C00,COZ	460-3	1	18	25	10	10								
C09		1	18	25	10	10								
C15		1	27	30	10	10								

① Maximum size of the time delay fuse or HACR type circuit breaker for protection of field wiring conductors.

② Based on 75C copper wire. All wiring must conform to the National Electrical Code and all local codes.

③ These "Minimum Circuit Ampacity" values are to be used for sizing the field power conductors. Refer to the National Electrical code (latest version), Article 310 for power conductor sizing.

Caution: When more than one field power circuit is run through one conduit, the conductors must be derated. Pay special attention to note 8 of Table 310 regarding Ampacity Adjustment Factors when more than three (3) current carrying conductors are in a raceway.

IMPORTANT: While this electrical data is presented as a guide, it is important to electrically connect properly sized over-current protection and conductor wires in accordance with the National Electrical Code and all local codes.

Indoor Blower Performance (60 Hz) - CFM at Rated Voltage

Speed	W18			W24			W30			W36			W42			W48			W60			W72		
	High	Low ①	Single ①	High ①	Low	High ①	High ①	Low	High ①	High ①	Low	High ①	High ①	Low	High ①	High ①	Low	High ①	High ①	Low	High ①	High ①	Low	
ESP (Inch H2O)	Dry Coil	Wet Coil	Dry Coil	Dry Coil	Wet Coil	Dry Coil	Dry Coil	Wet Coil	Dry Coil	Dry Coil	Wet Coil	Dry Coil	Dry Coil	Wet Coil	Dry Coil	Dry Coil	Wet Coil	Dry Coil	Dry Coil	Wet Coil	Dry Coil	Dry Coil	Wet Coil	
0.0	985	720	1010	975	1445	1380	940	930	1400	1310	965	955	1980	1940	1800	1705	2000	1940	1750	1700	2105	1540	1460	
0.1	965	700	690	925	1385	1320	930	920	1340	1260	940	930	1905	1880	1700	1640	1910	1865	1675	1615	2045	1480	1395	
0.2	935	665	660	905	1305	1240	920	910	1265	1185	905	890	1820	1760	1615	1565	1820	1770	1600	1540	1970	1885	1400	
0.3	880	635	625	835	1220	1150	895	880	1180	1100	860	850	1735	1665	1530	1450	1720	1605	1500	1425	1895	1800	1300	
0.4	795	590	575	750	1125	1055	850	830	1080	1010	800	785	1615	1565	1425	1350	1575	1500	1375	1320	1800	1700	1150	
0.5	680	520	510	640	1020	950	785	750	970	895	705	680	1510	1380	1100	1000	1420	1190	1075	1030	1705	1605	1110	

① Factory Connected Speed.

Above data is with 1" standard throwaway filter and 1" washable filter.
 For optional 2" pleated filter - reduce ESP by .15 in.
 See installation instructions for maximum ESP information on various KW application.

Electric Heat Table - Refer to Electrical Specifications for Availability by Unit Model

Nominal KW	At 240V (1)				At 208V (1)				At 480V (2)				At 460V (2)				
	Kw	1-Ph Amps	3-Ph Amps	Btuh	Kw	1-Ph Amps	3-Ph Amps	Btuh	Kw	3-Ph Amps	Btuh	Kw	3-Ph Amps	Btuh	Kw	3-Ph Amps	Btuh
4.0	4.0	16.7		13,652	3.00	14.4		10,239									
5.0	5.0	20.8		17,065	3.75	18.0		12,799									
6.0	6.0		14.4	20,478	4.50		12.5	15,359	6.0	7.2	20,478	5.52	6.9	18,840			
8.0	8.0	33.3		27,304	6.00	28.8		20,478									
9.0	9.0		21.7	30,717	6.75		18.7	23,038	9.0	10.8	30,717	8.28	10.4	28,260			
10.0	10.0	41.7		34,130	7.50	36.1		25,598									
15.0	15.0	62.5	36.1	51,195	11.25	54.1	31.2	38,396	15.0	18.0	51,195	13.80	17.3	47,099			
18.0	18.0		43.3	61,434	13.50		37.5	46,076	18.0	21.7	61,434	16.56	20.8	56,519			
20.0	20.0	83.3		68,260	15.00	72.1		51,195									

(1) These electric heaters are available in 230/208V units only.
 (2) These electric heaters are available in 480V units only.

Heater Packages - Field Installed "A" Series Right-Hand Units

- Designed for adding Electric Heat to 0 KW Units
- ETL US & Canada Listed
- Circuit Breaker Standard on 230/208V Models
- Toggle Disconnect Standard on 460V Models

Air Conditioner Models	-A00 Models 230/208-1		-B00 Models 230/208-3		-C00 Models 460-3	
	Heater Model #	KW	Heater Model #	KW	Heater Model #	KW
W18AA	EHW2TA-A05 EHW2TA-A08 EHW2TA-A10	5 8 10	N/A		N/A	
W24AA	EHWA24-A04B EHW2TA-A05 EHW2TA-A08 EHW2TA-A10	4 5 8 10	EHW2TA-B06	6	EHW24B-C06	6
W30AA	EHW3TA-A05 EHW3TA-A08 EHW3TA-A10 EHW3TA-A15	5 8 10 15	EHW30A-B06 EHW3TA-B09 EHW3TA-B15	6 9 15	EHW3TA-C06 EHW3TA-C09 EHW3TA-C12 EHW3TA-C15	6 9 12 15
W36AA	EHW3TA-A05 EHW3TA-A08 EHW3TA-A10 EHW3TA-A15	5 8 10 15	EHW3TA-B06 EHW3TA-B09 EHW3TA-B15	6 9 15	EHW3TA-C06 EHW3TA-C09 EHW3TA-C12 EHW3TA-C15	6 9 12 15
W42AA W48AA	EHW4TA-A05 ① EHWA05-A10B ① EHWA05-A15B EHWA05-A20B	5 10 15 20	EHWA05-B09B ① EHWA05-B15B EHW4TA-B18 ①	9 15 18	EHW4TA-C09 ① EHW4TA-C15	9 15
W60AA	EHW5TA-A05 ① EHWA05-A10B ① EHWA05-A15B EHWA05-A20B	5 10 15 20	EHW60A-B09B ① EHWA05-B15B ① EHW5TA-B18 ①	9 15 18	EHW4TA-C09 ① EHW4TA-C15	9 15
W72AA	EHW5TA-A05 EHW72A-A10B EHW72A-A15B EHW72A-A20B	5 10 15 20	EHW70A-B09B EHWA05-B15B EHW6TA-B18	9 15 18	EHW4TA-C09 EHW4TA-C15	9 15

① These heater packages approved for use in dehumidification versions with hot gas reheat.

Heater Packages - Field Installed "L" Series Left-Hand Units

Air Conditioner Models	-A00 Models 230/208-1		-B00 Models 230/208-3		-C00 Models 460-3	
	Heater Model #	KW	Heater Model #	KW	Heater Model #	KW
W18LA	EHW2TA-A05L EHW2TA-A08L EHW2TA-A10L	5 8 10	N/A		N/A	
W24LA	EHW2TA-A05L EHW2TA-A08L EHW2TA-A10L	5 8 10	EHW2TA-B06L	6	N/A	
W30LA	EHW3TA-A05L EHW3TA-A08L EHW3TA-A10L EHW3TA-A15L	5 8 10 15	EHW3TA-B09L EHW3TA-B15L	9 15	EHW3TA-C09L EHW3TA-C15L	9 15
W36LA	EHW3TA-A05L EHW3TA-A10L EHW3TA-A15L	5 10 15	EHW3TA-B09L EHW3TA-B15L	9 15	EHW3TA-C09L EHW3TA-C15L	9 15
W42LA W48LA	EHW4TA-A05L EHWA05-A10LB EHWA05-A15LB	5 10 15	EHWA05-B09LB EHWA05-B15LB	9 15 18	EHW4TA-C09L EHW4TA-C15L	9 15
W60LA	EHW4TA-A05L EHWA05-A10LB EHWA05-A15LB	5 10 15	EHWA60-B09LB EHWA05-B15LB	9 15	EHW4TA-C09L EHW4TA-C15L	9 15
W72LA	EHW6TA-A05L EHW72A-A10LB EHW72A-A15LB	5 10 15	EHW70A-B09LB EHWA05-B15LB	9 15	EHW4TA-C09L EHW4TA-C15L	9 15

Clearances Required for Service Access and Adequate Condenser Inlet Airflow

MODELS	LEFT SIDE	RIGHT SIDE
W18LA, W24LA, W30LA, W36LA	15"	20"
W42LA, W48LA, W60LA, W72LA	20"	20"

NOTE: For side-by-side installation of two (2) WL models, there must be 20" between units. This can be reduced to 15" by using a WL model (left side compressor and controls) for the left unit and WA (right side compressor and controls) for right unit.

Minimum Clearances Required to Combustible Materials

MODELS ①	SUPPLY AIR DUCT FIRST THREE FEET	CABINET
W18LA, W24LA	0"	0"
W30LA, W36LA	1/4"	0"
W42LA, W48LA, W60LA, W72LA	1/4"	0"

① Refer to the Installation Manual for more detailed information.

Dimensions of W18-72L Basic Unit for Architectural & Installation Requirements (Nominal)

MODEL	WIDTH (W)	DEPTH (D)	HEIGHT (H)	SUPPLY		RETURN																
				A	B	C	B	E	F	G	I	J	K	L	M	N	O	P	Q	R	S	T
W18LA W24LA	33.300	17.125	74.563	7.88	19.88	11.88	19.88	35.00	10.88	29.75	20.56	30.75	32.06	33.25	31.00	2.63	34.13	26.06	10.55	4.19	12.00	9.00
W30LA W36LA	38.200	17.125	74.563	7.88	27.88	13.88	27.88	40.00	10.88	29.75	17.93	30.75	32.75	33.25	31.00	2.75	39.13	26.75	9.14	4.19	12.00	9.00
W42LA W48LA	42.075	22.432	84.875	9.88	29.88	15.88	29.88	43.88	13.56	31.66	30.00	32.68	26.94	34.69	32.43	3.37	43.00	23.88	10.00	1.44	16.00	1.88
W60LA W72LA	42.075	22.432	93.000	9.88	29.88	15.88	29.88	43.88	13.56	37.00	30.00	40.81	35.06	42.81	40.56	3.37	43.00	31.00	10.00	1.44	16.00	10.00

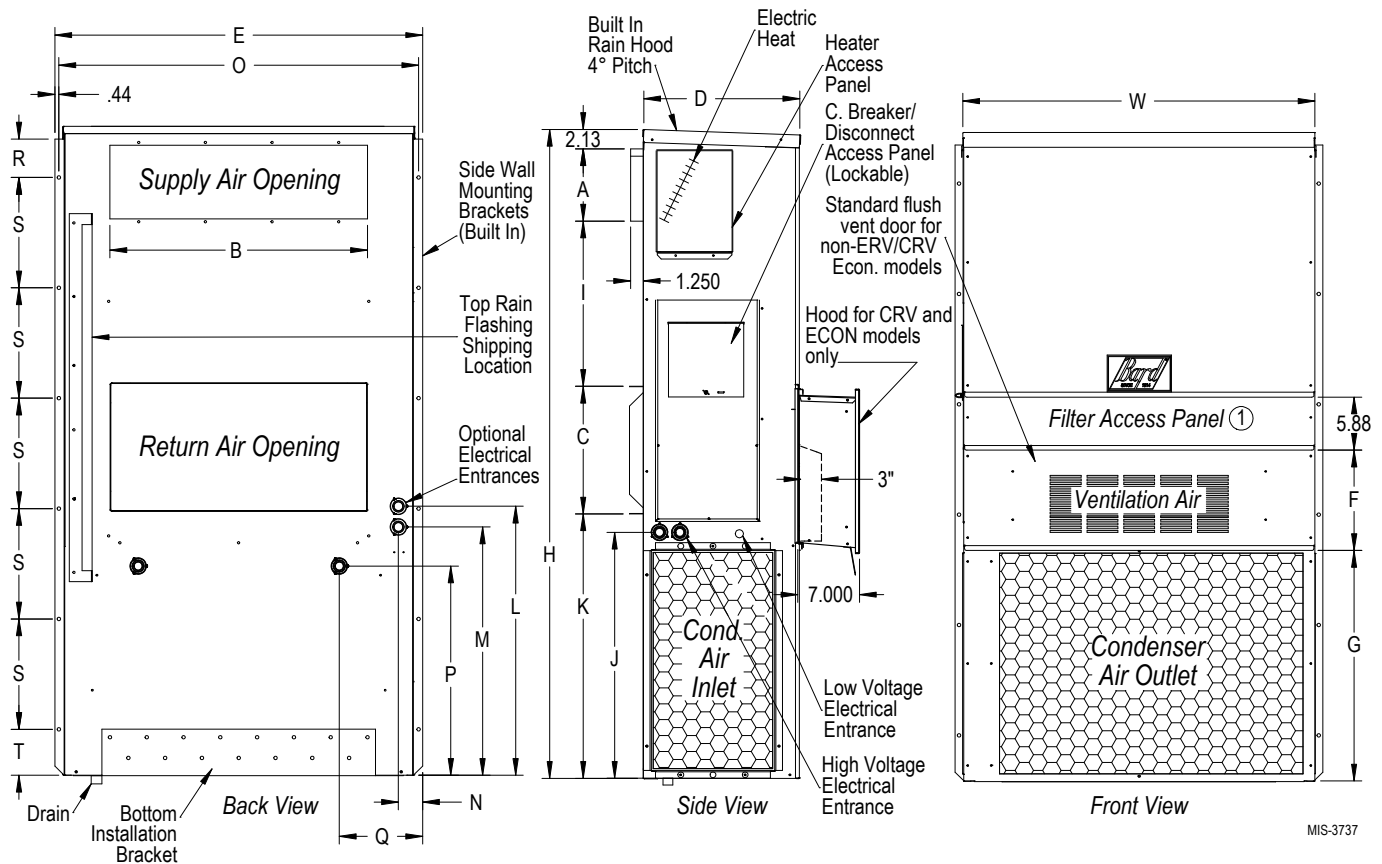

MIS-3737

① Not used when WECO Economizers installed. Filter access is through the WECO hood.

Cooling Application Data - Outdoor Temperature ①

Model	Return Air (DB/WB) ②	Cooling Capacity	75°F	80°F	85°F	90°F	95°F	100°F	105°F	110°F	115°F	120°F	125°F
W18	75/62	Total Cooling	17400	16700	16200	15500	14800	14300	13600	12900	12300	11700	11000
		Sensible Cooling	13900	13700	13600	13400	13200	13000	12800	12500	12100	11600	11000
	80/67	Total Cooling	18500	18200	17900	17500	17000	16600	16000	15400	14800	14100	13300
		Sensible Cooling	13400	13400	13400	13400	13300	13200	13100	12900	12600	12400	12000
	85/72	Total Cooling	22100	21300	20600	19800	18900	18200	17300	16400	15600	14700	13700
		Sensible Cooling	13800	13600	13500	13300	13100	12800	12500	12100	11600	11200	10700
W24	75/62	Total Cooling	28100	26000	24100	22400	20900	19800	18800	18000	17300	16900	16600
		Sensible Cooling	22100	20600	19400	18400	17600	16900	16500	16200	16000	16000	15900
	80/67	Total Cooling	30000	28300	26700	25300	24600	23000	22100	21400	20800	20400	20200
		Sensible Cooling	21400	20200	19200	18400	17700	17200	16900	16700	16600	16700	17000
	85/72	Total Cooling	35800	33100	30700	28600	26700	25200	23900	22800	21900	21200	20800
		Sensible Cooling	21900	20500	19300	18300	17400	16700	16100	15700	15300	15100	15100
W30	75/62	Total Cooling	32500	30800	29100	27600	26100	24900	23700	22600	21500	20600	19600
		Sensible Cooling	24500	23600	22800	22100	21400	20900	20400	19900	19500	19200	18900
	80/67	Total Cooling	34700	33500	32300	31200	30000	29000	27900	26900	25800	24900	23900
		Sensible Cooling	23700	23100	22600	22100	21600	21200	20900	20500	20300	20100	19900
	85/72	Total Cooling	41400	39200	37100	35300	33400	31700	30100	28600	27100	25900	24600
		Sensible Cooling	24300	23500	22700	22000	21200	20500	19900	19200	18700	18200	17600
W36	75/62	Total Cooling	39500	37300	35200	33500	31800	30400	29100	27900	26900	26000	25200
		Sensible Cooling	29100	28100	27200	26300	25600	25000	24400	23900	23600	23200	22900
	80/67	Total Cooling	42100	40600	39100	37800	36400	35400	34300	33300	32300	31500	30700
		Sensible Cooling	28200	27500	26900	26300	25800	25400	25000	24700	24500	24300	24100
	85/72	Total Cooling	50200	47500	44900	42700	40600	38700	37000	35500	34000	32800	31600
		Sensible Cooling	28900	27900	27000	26100	25300	24600	23900	23200	22600	22000	21300
W42	75/62	Total Cooling	43600	41600	39700	38000	36200	34500	32900	31300	29800	28300	26900
		Sensible Cooling	34000	33200	32200	31400	30600	29900	29200	28600	27900	27300	26700
	80/67	Total Cooling	46500	45300	44100	42900	41500	40200	38800	37300	35800	34300	32700
		Sensible Cooling	33000	32500	31900	31400	30900	30400	29900	29500	29000	28600	28100
	85/72	Total Cooling	55400	53000	50700	48500	46100	44000	41900	39700	37600	35700	33700
		Sensible Cooling	33800	33000	32100	31200	30300	29400	28500	27700	27000	25900	24900
W48	75/62	Total Cooling	50500	48200	46000	43900	41800	39900	38000	36100	34400	32700	31000
		Sensible Cooling	38700	37800	36900	35900	35100	34200	33400	32500	31700	31000	30100
	80/67	Total Cooling	53900	52500	51100	49600	48000	46500	44800	43100	41400	39600	37800
		Sensible Cooling	37500	37000	36500	35900	35400	34800	34200	33600	33000	32400	31700
	85/72	Total Cooling	64200	61400	58700	56000	53300	50900	48300	45900	43500	41200	38900
		Sensible Cooling	38400	37600	36700	35700	34700	33700	32600	31500	30400	29300	28100
W60	75/62	Total Cooling	65500	61900	58400	55000	51800	48800	45900	43100	40500	37900	35300
		Sensible Cooling	49600	48200	46800	45300	43900	42500	41000	39600	38300	36800	35300
	80/67	Total Cooling	69900	67400	64800	62200	59000	56900	54200	51400	48700	45900	43000
		Sensible Cooling	48100	47200	46300	45300	44300	43200	42100	40900	39800	38500	37300
	85/72	Total Cooling	83300	78800	74400	70200	66100	62200	58400	54700	51200	47700	44200
		Sensible Cooling	49300	47900	46500	45000	43500	41800	40100	38400	36700	34800	33000
W72	75/62	Total Cooling	73800	70800	67800	64800	61800	59000	56100	53200	50400	47600	44800
		Sensible Cooling	55500	54000	52400	51000	49500	48200	46900	45600	44400	43200	42000
	80/67	Total Cooling	78800	77100	75300	73200	71000	68700	66200	63500	60700	57700	54600
		Sensible Cooling	53800	52900	51900	51000	50000	49100	48100	47100	46200	45200	44200
	85/72	Total Cooling	93900	90100	86500	82600	78900	75100	71400	67600	63800	60000	56200
		Sensible Cooling	55100	53700	52100	50700	49000	47500	45800	44200	42600	40800	39100

① Below 65°F (18.3C), unit requires a factory or field installed low ambient control.

② Return air temperature.

Capacity Multiplier Factors			
% of Rated Airflow	-10	Rated	+10
Total BTUH	0.975	1.0	1.02
Sensible BTUH	0.950	1.0	1.05

Air Conditioning Wall-Mount Model Nomenclature

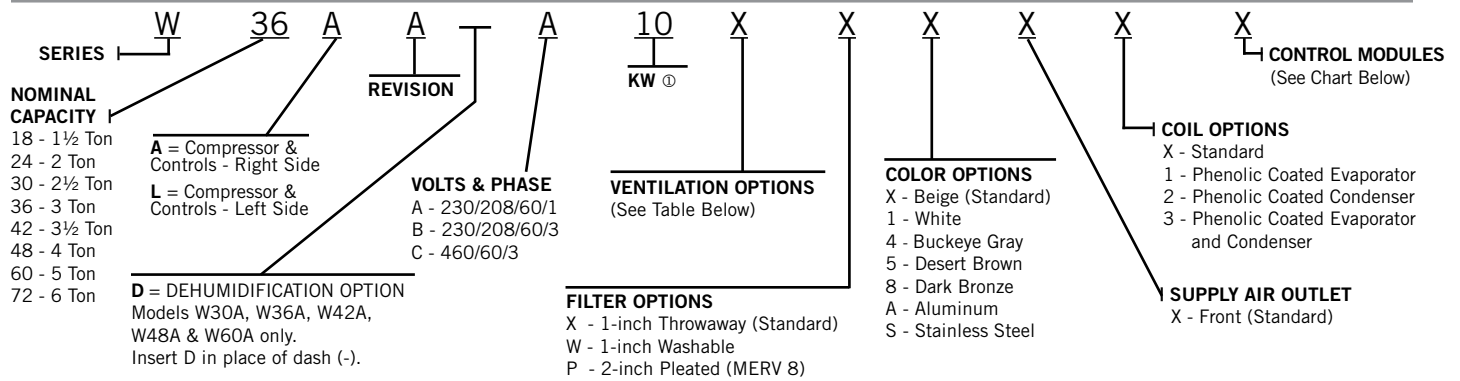

① For OKW and circuit breakers (230/208 Volt) or toggle disconnects (460 Volt) applications, insert OZ in the KW field of the model number. See Pages 8 & 9 for available Factory Installed KW options and Page 11 for Field Installed Heater Packages.

Ventilation Options

Models	W18AA, W24AA W18LA, W24LA		W30AA, W36AA W30LA, W36LA		W42AA, W48AA, W60AA, W72AA W42LA, W48LA, W60LA, W72LA	
	Factory Installed Code No.	Field Installed Part No.	Factory Installed Code No.	Field Installed Part No.	Factory Installed Code No.	Field Installed Part No.
Barometric Fresh Air Damper - Standard	X	WBFAD-2	X	WBFAD-3	X	WBFAD-5
Blank-Off Plate	B	WBOP-2	B	WBOP-3	B	WBOP-5
Motorized Fresh Air Damper w/Plug	M	WMFADP2	M	WMFADP3	M	WMFADP5
Commercial Ventilator - Spring Return w/Plug & Exhaust ③	V	WCRVPS2-* ②	V	WCRVPS3-* ②	V	WCRVPS5-* ②
Economizer w/Plug, Temp Only ③	Y	WECOPT2-* ②	Y	WECOPT3-* ②	Y	WECOPT5-* ②
Economizer w/Plug, Enthalpy ③	Z	WECOPE2-* ②	Z	WECOPE3-* ②	Z	WECOPE5-* ②
Energy Recover Ventilator w/Plug, 230 Volt	R	WERVPA2-* ①	R	WERVPA3-* ①	R ④	WERVPA5-* ①
Energy Recover Ventilator w/Plug, 460 Volt	R	WERVPC2-* ①	R	WERVPC3-* ①	R ④	WERVPC5-* ①

- ① Intake and exhaust can be independently adjusted.
- ② Insert color to match unit ("X" = Beige; "4" = Buckeye Gray; etc.)
- ③ All Economizer & CRV versions have 7" deep intake hood.
- ④ Energy Recovery Ventilator must be field-installed on W**L models.

Air Conditioning Control Modules

Air Conditioning Control Modules									All Models Except As Noted	
HPC ①	LPC ②	CCM ③	LAC ④	ALR ⑤	SK ⑥	SK ⑦	ODT ⑧	DDC ⑨	Factory Installed Code	Field Installed Part
STD	STD	STD							X	N/A
STD	STD	STD	•						E	CMA-28
STD	STD	STD	•	•					J	Factory Only
STD	STD	STD	•		•				K	CMC-15 and CMA-28
STD	STD	STD	•	•	•				M	Factory Only
STD	STD	STD		•					N	N/A
STD	STD	STD			•				Field Installed Only	CMC-15
STD	STD	STD					•		Field Installed Only	CMA-14
STD	STD	STD	•	•				•	V ⑩	Factory Only
STD	STD	STD						•	Field Installed Only	CMA-31 for W18-36 CMA-30 for W42-72
STD	STD	STD				•			Field Installed Only	SK111 Except W60 & 72 SK121 W72 Only SK122 W60 Only

STD = Standard equipment for these specified models.

- ① HPC. High pressure control is auto reset. Always used with compressor control module (CCM) which is included. See note ③.
- ② LPC. Low pressure control is auto reset. Always used with compressor control module (CCM) which is included. See note ③.
- ③ CCM. Compressor control module has adjustable 30-second to 5-minute delay-on-break timer. On initial power-up, or any time the power is interrupted, the delay-on-make will be 2-minutes plus 10% of the delay-on-break setting. There is no delay-on-make during routine operation of the unit. The module also provides the lockout feature (with 1 retry) for high and/or low pressure controls, and a 2-minute timed bypass for low-pressure control.
- ④ LAC. Low ambient control permits cooling operation down to 0°F. LAC is fan-cycling control for outdoor fan motor on all models except W18/W24 Dehum. units, which have modulating control.
- ⑤ ALR. The alarm relay has a set of normally open and normally closed dry contacts to provide the ability to signal a condition of shutdown on either high or low pressure controls.
- ⑥ SK. PTCR start kit can be used with all -A single phase models. Increases starting torque 2-3x. Not used for -B or -C three phase models. Do not use if SK111 or SK121 is used.
- ⑦ SK. Start capacitor & potential relay start kit can be used with all -A single phase models. Increases starting torque 9x. Not used for -B or -C three phase models. Do not use if CMC-15 is used.
- ⑧ ODT. Outdoor thermostat is adjustable from 0 to 50°F. It is suitable for use as a compressor cut-off thermostat.
- ⑨ DDC. Incorporates 4 additional sensors: discharge air temperature, indoor blower airflow, compressor current, and dirty filter. These sensing devices function to input analog data such as temperature, as well as digital data such as airflow, compressor status or filter status. Special economizer required; consult factory.
- ⑩ "V" control module should be ordered in conjunction with direct digital controller (DDC) model TCS24. Refer to DDC specification sheet S3280 for more information.



Bard Manufacturing Company, Inc.
Bryan, Ohio 43506
www.bardhvac.com

Due to our continuous product improvement policy, all specifications subject to change without notice.

Before purchasing this appliance, read important energy cost and efficiency information available from your retailer.

**Form No.
S3502
December, 2015**

Supersedes S3502-715